

Folder Knives and Spare Parts

Precision and Perfection:

For optimal printing, folding and cutting processes



Our deep understanding of our customers' requirements in the printing and packaging industry forms the foundation of our knives and consumable parts for folders.

Whether made of tool steel, chrome steel, high-speed steel, carbide, whether coated or refined: With state-of-the-art technology TKM manufactures products and systems characterized by precision and especially high durability.

Intensive dialog builds the cornerstone of our services. Working together with you, we'll develop the best tools and systems for optimal integration in your folding and production processes.

Thanks to uncompromising quality management – from the procurement of raw materials to delivery – we can guarantee that the finishing of our tools will be free of deviations in tolerance.

In this way, we can offer perfect and tailor-made products and systems with measurable added value.

TKM, The Knife Manufacturers.

TKM customer groups

- Gravure printing
- Heatset – Offset
- Coldset – Offset

Contents

Overview

■ Folder knives and spare parts	4
Slitting	6
Perforating	7
Cross-cutting	8
Folding and guiding	10
Special products	12
Inline finishing	13

TKM-Service

■ Repair and regrinding services	14
■ User consulting and training	16

TKM worldwide

■ TKM Headquarters	18
■ TKM Meyer, production site	20

Folder Knives and Spare Parts

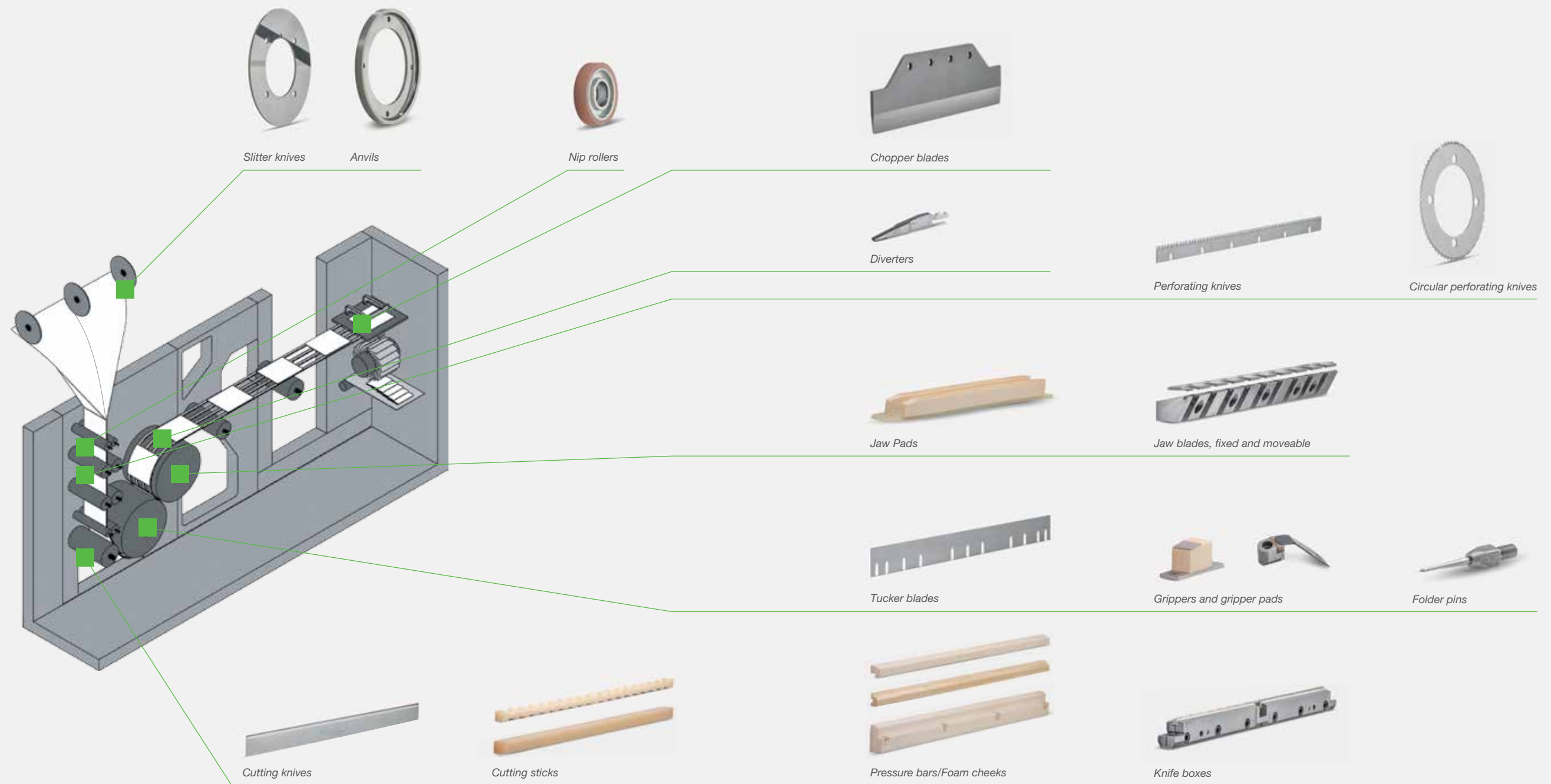

Working together. Cutting and folding as success factors.

In partnership with our customers, we specify our products and services for their various applications and requirements for cutting and folding solutions, such as:

- SurePerf
- Timed circular perforating knives
- Jaw pads with wear inserts
- Lapped knives for slitting
- S3 cutting knives
- Cutting bars made of Vulkollan®

What our customers appreciate: TKM's commitment.

- Coordinating tools and systems with an eye on production processes
- Together improving interfaces and processes
- Ensuring worldwide availability
- Delivering reliable and stable quality standards

Slitting

Circular knife

Besides optimal raw materials, the adjustment of the circular knives is a very important factor for obtaining a long service life and avoiding the formation of dust and web breaks.

To ensure long-term product quality of your systems, we can support you with training and seminars, in particular concerning setup adjustments.

Manufacturer's factors of influence

- | Materials | Design | Surface Characteristics |
|--|--|---|
| <ul style="list-style-type: none"> ■ Chrome steel ■ Tool steel ■ HSS ■ ASP ■ Hard metal | <ul style="list-style-type: none"> ■ Preliminary chamfer ■ Single chamfer ■ Without chamfer ■ Back angle | <ul style="list-style-type: none"> ■ Standard and lapped ■ Polished up to Ra 0.02 μ |



Circular knife with chamfer



Circular knife without chamfer



Anvil

TKM slitting knives are manufactured to the machine manufacturer's specifications or optimized according to individual customer requirements. Here we apply the following criteria:

- Cant angle
- Overlap
- Overspeed
- Cutting point
- Material
- Surface quality
- Design
- Knife holder

Perforating

Cross-perforating

TKM has a very wide range of perforating knives, which together with products for customer-specific applications, rounds off our product line.

SurePerf – folding without gussets

The SurePerf knives (a TKM patent) ensure production without gussets, even with large-paging.

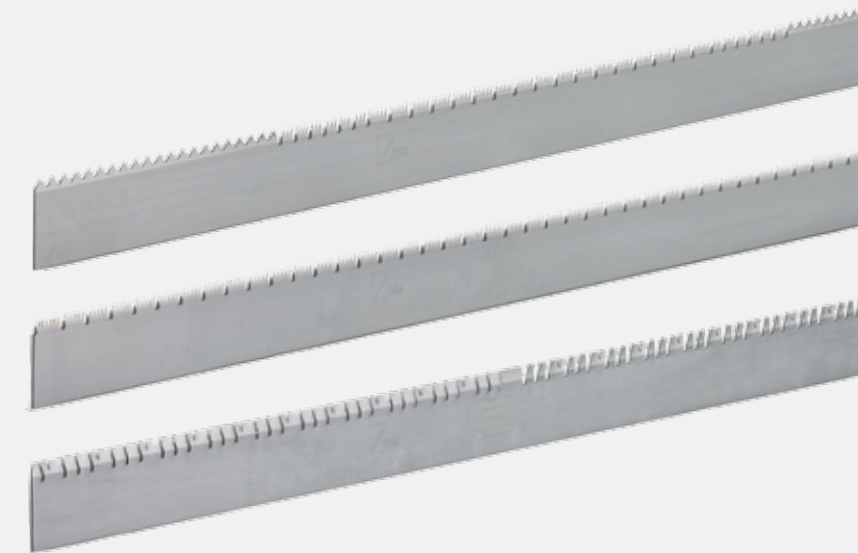

Longitudinal perforation

TKM manufactures different diameters and thicknesses. The tothing is adjusted to the product, making different types of tothing on a knife possible.

Chamfer

- Single chamfer (ground on one side)
- Double chamfer (ground on both sides)

Tooth shapes

- Pointed tooth
- Trapezoidal tooth
- Square tooth



Each circular perforating knife is available with single or double chamfer.



Pointed tooth



Trapezoidal tooth



Square tooth

Cross-cutting

Cutting knives

For an optimal durability the right cutting bar must be used with the right setting, in addition to using the right cutting knife!

Ask us about the best customer-specific cutting knife for your application!

Influence on service life

- Tooth type
- Tooth pitch
- Chamfer
- Raw material
- Setting
- Cutting bar

Tip

For final cutting already in the folder, we can manufacture cutting knives with up to 20 teeth per centimeter!



Versions:

Materials

- Spring steel
- S1
- S3

Tooth design

- Perforating tooth
- Saw tooth

Tooth pitch

- 0.5 mm to 4 mm
- Larger in special cases

Chamfers

- Single chamfer
- Double chamfer

Knives with S3 quality

Outstanding knife quality with extremely high wear resistance will increase service life many times over. That makes the use of these knives extremely economical.

Materials

Material	Hardness in HRC	Relative service life
Spring steel	49 - 52	1
S1	60 - 63	4 - 6
S3	62 +/- 1	6 - 10

Cross-cutting

Cutting sticks



Materials

Vulkollan® D15, other polyurethanes and rubber.

TIP

Chamfered edges make installation and turning of the cutting bar easier.



Pressure bars/Foam cheeks

We manufacture our pressure bars from cellular Vulkollan® in different profiles, exactly to fit your knife box.



Knife boxes

For a complete and process-consistent work procedure we also supply knife boxes, in addition to cutting knives and foam cheeks.



Setting gauges

For quick and precise installation of cutting and perforating knives in the knife box without additional measuring instruments (sliding gauges).

Cutting bars made from Vulkollan®

Vulkollan® excels itself with especially high abrasion and deformation resistance. It has a constant Shore hardness, resulting in a very high durability.

Folding

Tucker blades and chopper blades

TKM manufactures tucker blades for all common printing machines of different manufacturers and their tolerance specifications.

Materials

- Spring steel
- Tool steel
- S1

Available with different coatings on request.

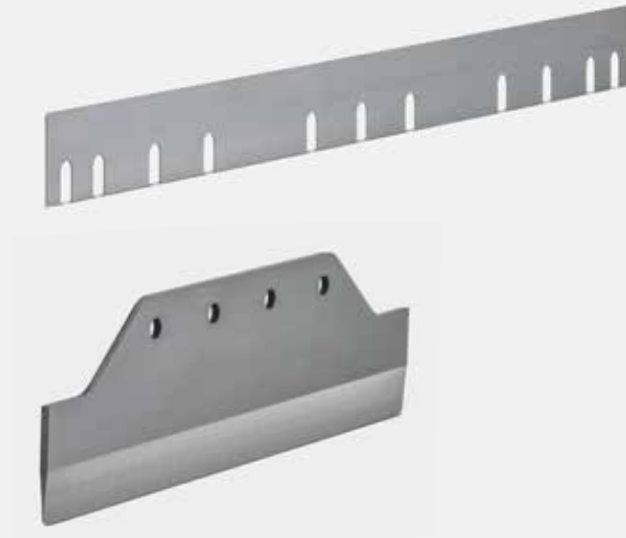

Jaw blades, fixed and movable

We consider jaw blades, fixed and moveable, as well as tucker blades, to be single units. In this way, we provide process-optimized solutions to our customers, each according to machine type and application. With a variety of steel grades and coating variations available, we have a broad spectrum of

fixed and movable jaw blades as well as tucker blades.

Our application engineers will be happy to assist you in the optimization of your processes.

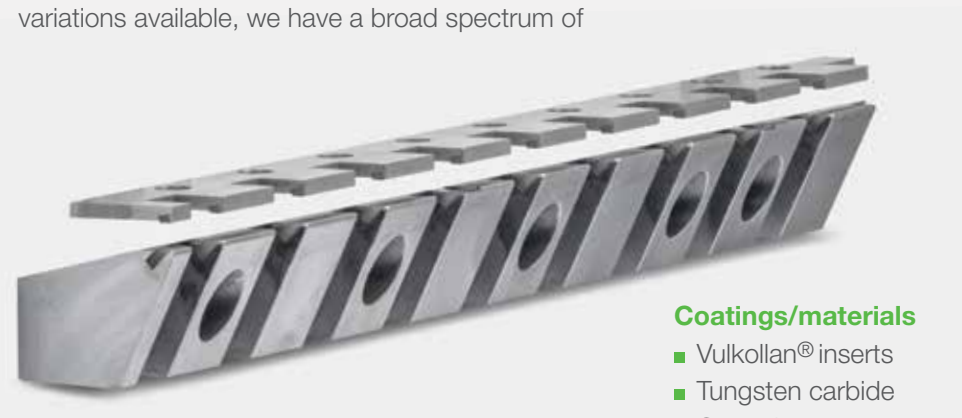

Coatings/materials

- Vulkollan® inserts
- Tungsten carbide
- Ceramics
- Plasma

Advantages

- Sustainable support through in-house processing
- Recoating within tolerance specifications
- Reliable and stable quality standards

Guiding



Folder pins

TKM offers a product line of around 500 different folder pins for all common types of machines, and supplies the corresponding folder pin wrenches.



Grippers/gripper pads

- Different designs
- Various materials
- Ceramics or tungsten carbide
- Vulkollan® inserts



Jaw pads

- Possible with wear insert
- For all common machine types
- Composite of spring steel and Vulkollan®



Diverters with non-stick properties

- High durability
- Renewable lining
- Materials: S green, Delrin, ski coating, POM and other plastics

Advantages

- Use of premium raw materials
- Ultra-precise adherence to manufacturing tolerances

Special products

Nip rollers

TKM manufactures nip rollers in all required dimensions, as well as special versions with aluminum or steel bodies. We use exclusively Vulkollan® for more precise results.

Advantages/characteristics

- Low wear and long service life
- Very high elasticity
- Resistant to inks and solvents
- Resistant to high temperatures
- Recoating possible
- Nip rollers also available with bearings



Wash-up blades



For TKM wash-up blades we generally use Vulkollan® in order to obtain minimum tolerance deviations. Vulkollan® provides a precise contact zone between wash-up blade and roller and resist swelling. Ink and cleaning agent residues are cleanly scraped off.

Depending on the application, the wash-up time is reduced by approximately 40 % compared with conventional steel-rubber wash-up blades. This leads to a saving of up to 50 % in detergents, as well as to clearly longer service lifetimes.

Inline finishing

Rotary trimmers

TKM rotary trimmers are offered for all commercially available rotary trimmers (Gämmerler, RIMA, Müller Martini etc.).

In addition to standard applications, TKM develops solutions that are specially tailored to customer-specific use.



Completing the TKM product line:

- Flock tape
- Stitcher parts
- Web severing knives
- Ink fountain blades
- Tape pulleys
- Brake cams

Advantages/features of TKM rotary trimmers

- Continuously variable, screwed hard-metal single blades
- Unlimited use of the milling body (no need for spare parts)
- Tight tolerances in runout (< 0.01 mm)
- Low friction coefficient through non-stick coating
- Reduction of ink and glue deposits
- Long service lifetimes when cutting shingle streams up to 15 mm in thickness
- Available for all commercial rotary trimmers

For the efficient use of our tools, we always stand at the side of our customers not only as a supplier and consultant, but as a reliable partner, through all phases of their daily business.

Collaborative Thinking and Support: Perfect consulting and accompaniment are obvious for us.

The careful advice of our specialists will assist you in selecting the right tools for your specific application.

Services

- Repair service
- Resharpener service
- User consulting
- Training

Repair and regrinding services



Due to the high in-house production depth of TKM it is possible to offer overhauling of cutting tools on a new-part accuracy level. Our service and quality are based on state-of-the-art technology and experienced professionals who will advise you specifically for your application.

Repair service

In addition to fixed and moveable jaw blades, we also repair gripper pads as well as diverters. You may expect TKM spare parts repaired by us (like fixed and moveable jaw blades, etc.) to comply with the same production tolerances as our new parts.

If necessary, we will replace the Vulkollan inserts or recoat the surfaces with different ceramic materials or tungsten carbide. We support preparation on request with measurement reports recording the condition of the component before and after the repair.

Resharpener service

Optionally, our circular knives can be designed with a specially polished finish on both sides. This makes for increased durability and less generation of dust.

For particularly high-quality surfaces, we lap the cutting tools – or grind them conventionally.

Advantages of lapped circular knives

- Optimum cross section
- Up to 40 % less dust
- Up to 4x longer service lifetimes than with comparable conventional knives
- Chunking on the knife is minimized

User consulting and training

User consulting

- Identification of actual status and technical consulting
- Development of a service concept
- Service routing and sustainability
- Documentation, analysis, research and development

Training

On request we can also carry out application-specific training at your place of business. We take into account your specific requirements and actively assist you in improving quality, efficiency and profitability – for all printing and postpress processes.



Training topics

- Application-specific training
- Technical cutting seminars
- Circular knife training

Close by – Worldwide.

The TKM group builds a system of production expertise.
We create added value – far beyond cutting, printing and postpress processing.

Throughout the world, we share together the consistently pursued aim of innovation and new technologies, as is reflected by the abilities of our workers and employees.

As a network, we utilize the potential of our local companies, which lay the foundations for our first-class service, high flexibility and personal consulting on site.

As developers and manufacturers of products and systems, we will passionately look for the optimal solution for you.

- TKM headquarters
- TKM Meyer. Production site and center of excellence for printing and packaging
- TKM subsidiaries
- Sales partners and distributors

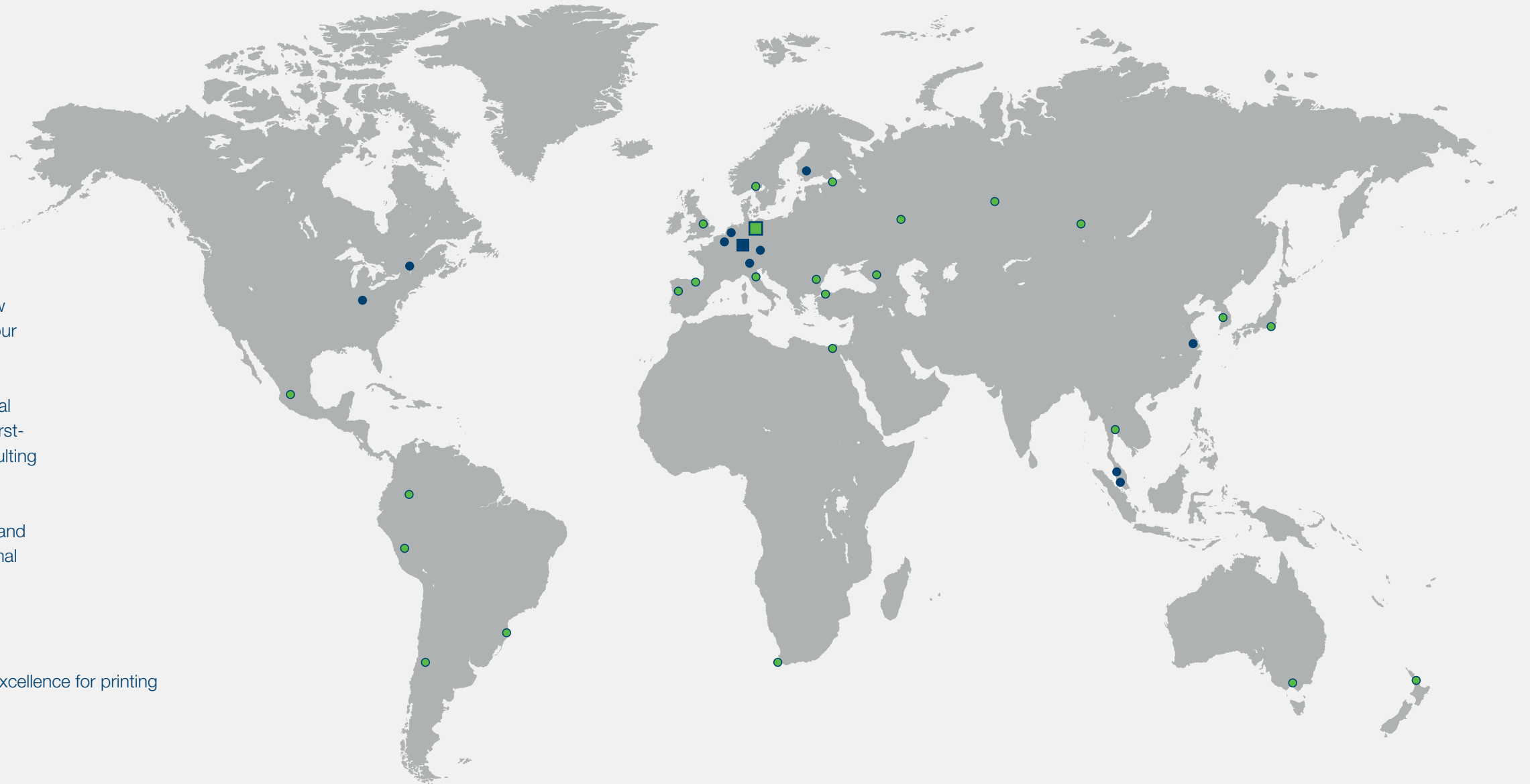

TKM

Telephone: +49 (0) 2191 969 0
Remscheid, Germany

TKM Geringswalde

Telephone: +49 (0) 37382 846 0
Geringswalde, Germany

TKM Meyer

Telephone: +49 (0) 4532 400 0
Bargteheide, Germany

TKM Austria

Telephone: +43 (0) 7442 601 0
Böhlerwerk, Austria

TKM Diacarb

Telephone: +31 (0) 1045 999 45
Capelle aan den IJssel,
Netherlands

TKM France

Telephone: +33 (0) 328 350 800
Bondues, France

TKM TTT Finland

Telephone: +358 (0) 201 240 288
Akaa/Toijala, Finland

TKM China

Telephone: +86 (21) 5986 905 0
Shanghai, China

TKM Blades Malaysia

Telephone: +60 (3) 7875 - 7669
Selangor, Malaysia

TKM Singapore

Telephone +60 (3) 7875 - 7669
Singapore

TKM US

Telephone: +1 (859) 689 709 4
Erlanger, United States of America

TKM Canada

Telephone: +1 (450) 378 196 5
Saint-Alphonse-de-Granby,
Canada

TKM Headquarters Remscheid

TKM, the internationally leading corporate group, manufactures and sells high-quality industrial knives, saws, doctor blades and precision consumable parts for industrial applications.

Our technologies, products and industrial services are applied and appreciated worldwide across many industries. As an independent family company, we have been setting the standards in quality and

innovation, technical expertise and close cooperation for over 100 years.

Reliability, integrity and commitment are the hallmarks of our collaboration. We define our claims to excellence in terms of these fundamental values by being:

Innovative, precise and close by.



TKM Meyer The specialist for printing and packaging

TKM Meyer is the development, manufacturing and service center for doctor blades as well as for knives and consumable parts for the printing and packaging industry.

Together with the Remscheid site, TKM Meyer constitutes the center of excellence in the paper division for the paper, printing and packaging industry as well for postpress.

The high in-house production level is the basis for the excellent stock availability and supports our comprehensive service ideas.

Specific product and system developments can be implemented locally. Care, maintenance and repair of tools round off our services, thus ensuring a stable tool quality and long machine service lifetimes.



Innovative:

We strive for new technology and continuously develop products and processes, in order to produce the highest performing Industrial machine knives and cutting tools.

Precise:

Our products, services and technical ability all help benefit our customers processes, productivity and finally finished product to assist in their operational development.

Close by:

Our philosophies are sustainable and stand for a balance between environmental measures, economic development and social engagement.

No matter where you are in the world a TKM subsidiary or partner is never far away.

TKM Meyer

- 150 employees – 10 % trainees
- 83 tool machines – 52 % CNC machines
- 6,500 m² of production and storage space
- Products: 55 % packaging industry, 45 % commercial printing
- Batches of 1 to 2,500
- Production volume: 300,000 parts/year



TKM
TKM Geringswalde
TKM Meyer
TKM Diacarb
TKM France
TKM Austria
TKM TTT Finland
TKM US
TKM Canada
TKM China
TKM Blades Malaysia
TKM Singapore

Center of excellence for printing and packaging

TKM Meyer GmbH
Heinrich-Hertz-Str. 17
22941 Bargtheide/Germany

Phone: +49 (4532) 400-0
info@tkmmeyer.com
www.tkmmeyer.com

Headquarters

TKM GmbH
In der Fleute 18
42897 Remscheid/Germany

Phone: +49 (2191) 969-0
info@tkmgroup.com
www.tkmgroup.com